

Easyclad®

Steel wall cladding
system

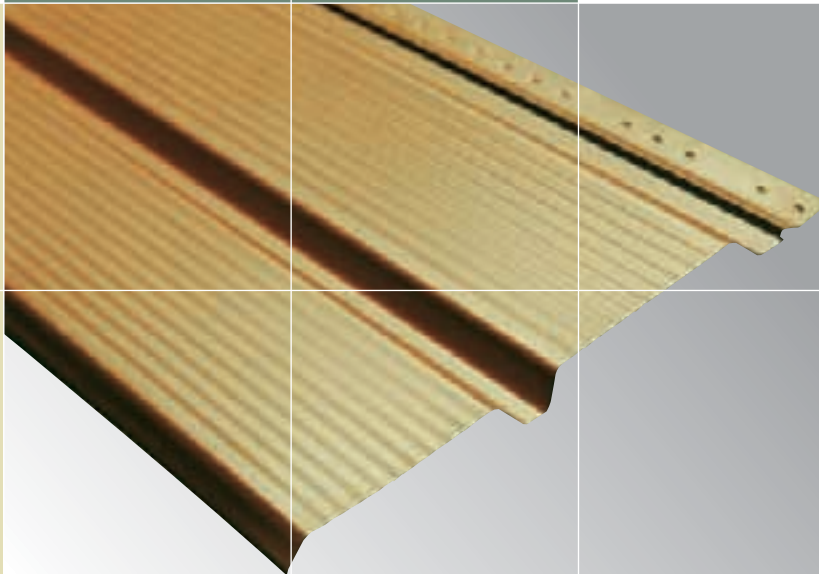

- Stylish, clean-line panels with a wide range of trim sections and accessories
- Versatile panels can run vertically or horizontally
- Wide range of trim sections and accessories are available
- High impact resistance due to profile strength
- Range of COLORBOND® steel colours available

LYSAGHT

Lysaght Easyclad®

LYSAGHT EASYCLAD® wall cladding is a stylish solution for both interior and exterior steel walling applications. It's easy 'secret' fix system helps provide stylish clean lines for an uninterrupted weatherboard-like appearance. Incorporating a wide range of trim sections and accessories, EASYCLAD walling is suitable in various design situations.

EASYCLAD is used for walling in non-cyclonic industrial, commercial and domestic areas. Refer to your local BlueScope Lysaght office for more information.

Colours

EASYCLAD is available in COLORBOND® factory pre-painted steel and in unpainted ZINCALUME® aluminium/zinc alloy coated steel.

ZINCALUME steel and COLORBOND steel provides a minimum of twice the life of conventional galvanised steel in the same environment.

Standard COLORBOND® steel is available in a full range of contemporary colours suitable for all building projects. COLORBOND® Metallic finish steel provides superior aesthetic qualities, and COLORBOND® Ultra steel is intended for severe coastal or industrial environments.

Masses

EASYCLAD 2PF300

BMT (mm)	kg/m	kg/m ²	m ² /t
0.42 ZINCALUME steel	1.35	4.51	222
0.42 COLORBOND steel	1.38	4.59	218

Material Specifications

EASYCLAD is manufactured from ZINCALUME zinc/aluminium alloy-coated steel complying with AS1397-G550-AZ150 (550MPa minimum yield strength, 150 g/m² minimum coating mass as determined by the prescribed triple spot test).

The COLORBOND prepainted steel complies with AS/NZS-2728:1997.

Lengths

Sheets are supplied custom cut.

Tolerance

Length: +0mm, -15mm
Width: +3mm, -3mm

Sheet coverage

Height of wall (m)	3	4	5	6	7	8	9	10	11	12	13	14	15	16	17	18	19	20	30	40	50
Number of sheets	10	14	17	20	24	27	30	34	37	40	44	47	50	54	57	60	64	67	100	134	167

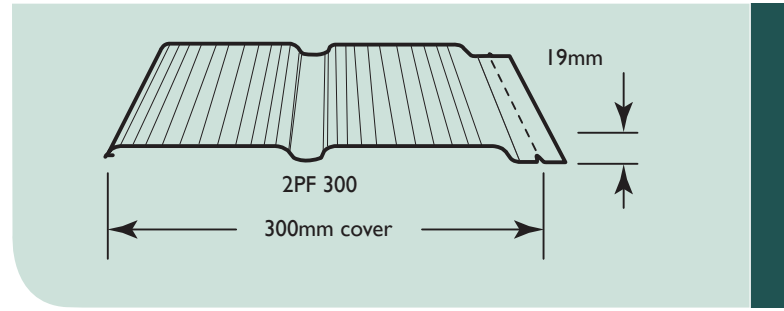

Maximum Wall Support

Spacings for LYSAGHT EASYCLAD 2PF300

Type of Span	2PF300
End Span	1500
Internal Span	1500

- For walls: the data are based on pressures (see wind pressures table).
- Table data are based on supports of 1mm BMT.

Maximum Support Spacings

The maximum recommended support spacings are based on testing in accordance with AS1562.1-1992 and AS4040.2-1992.

Wall spans consider resistance to wind pressure only.

The pressure considered is based on buildings up to 10m high in Region B, Terrain Category 3, $M_s=0.85$, $M_l=1.0$, $M_t=1.0$ with the following assumptions made:

Walls:

$C_{pe}=+0.20$, $C_{pe}=-0.65$, $K_1=2.0$ for single spans, $K_1=1.5$ for internal spans.

These spacings may vary by serviceability and strength limit states for particular projects.

LYSAGHT EASYCLAD® 2PF 300: Limit State wind pressure capacities

Type of Span	Limit State	Span(mm)							
		450	600	750	900	1050	1200	1350	1500
Base Metal Thickness 0.42mm									
End	Serviceability	1.39	1.36	1.33	1.28	1.23	1.17	1.10	1.04
	Strength*	4.85	3.85	3.10	2.50	2.20	2.00	1.85	1.80
Internal	Serviceability	1.28	1.26	1.23	1.20	1.15	1.11	1.05	1.01
	Strength*	4.85	3.85	3.10	2.50	2.20	2.00	1.85	1.80

* A capacity reduction factor of $\phi = 0.9$ has been applied to strength capacities. Supports must be not less than 1mm BMT.

Limit states wind pressures

LYSAGHT EASYCLAD steel cladding offers the full benefits of the latest methods for modelling wind pressures. The Wind Pressure Capacity table is determined by full scale tests conducted at BlueScope Lysaght's NATA-registered testing laboratory, using the direct pressure testing rig.

Testing was conducted in accordance with AS-1562.1—1992 Design and installation of sheet roof and wall cladding—Metal, and AS-4040.2—1992 Resistance to Wind Pressures for Non-cyclonic Regions.

The pressure capacities for service-ability are based on a deflection limit of $(\text{span}/120) + (\text{maximum fastener pitch}/30)$.

The pressure capacities for strength have been determined by testing the cladding to failure (ultimate capacity). These pressures are applicable when the cladding is fixed to a minimum of 1.0mm, G550 steel.

For material less than 1.0mm thick, seek advice from our information line.

Compatibility

Lead, copper, bare steel and green or some chemically-treated timbers are not compatible with this product; thus don't allow any contact of the product with those materials, nor discharge of rainwater from them onto the product. If there are doubts about the compatibility of products being used, ask for advice from our information line.

Maintenance

Optimum product life will be achieved if all external surfaces are washed regularly. Areas not cleaned by natural rainfall (such as the tops of walls sheltered by eaves) should be washed down every six months.

Safety, storage and handling

LYSAGHT product may be sharp and heavy. It is recommended that heavy-duty cut resistant gloves and appropriate manual handling techniques or a lifting plan be used when handling material.

Keep the product dry and clear of the ground. If stacked or bundled product becomes wet for extended periods, separate it, wipe it with a clean cloth and stack it to dry thoroughly.

Handle materials carefully to avoid damage: don't drag materials over rough surfaces or each other; carry tools, don't drag them; protect from swarf.

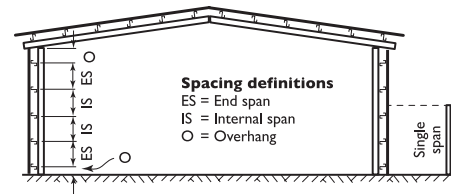

Cutting

For cutting thin metal on site, we recommend a circular saw with a metal-cutting blade because it produces fewer damaging hot metal particles and leaves less resultant burr than a carborundum disc.

Cut materials over the ground and not over other materials.

Sweep all metallic swarf and other debris from roof areas and gutters at the end of each day and at the completion of the installation. Failure to do so can lead to surface staining when the metal particles rust.

Sealed joints

For sealed joints use screws or rivets and neutral-cure silicone sealant branded as suitable for use with galvanised or ZINCALUME® steel.

Non-cyclonic areas

The information in this brochure is suitable for use only in areas where a tropical cyclone is unlikely to occur as defined in AS 1170.2—2002.

For information on the use of LYSAGHT products in cyclonic conditions, refer to the Cyclonic Area Design Manual which is available by ringing Steel Direct on 1800 641 417 or on our website: www.lysaght.com.



Lysaght Easyclad installation

Fastener without insulation for LYSAGHT EASYCLAD 2PF300

Steel Supports Up to 0.75mm thick

Self-drilling tapping screw with hex. washer-head
10-16x16 (M4.8-16x16)

Steel Supports 0.75mm to 3mm thick

Self-drilling tapping screw with hex. washer-head
10-16x16 (M4.8-16x16)

Timber Supports

Type 17 screws with hex. washer-head
Softwood: 10-12x30 (M4.8-12x30)
Hardwood: 10-12x20 (M4.8-12x20)

LYSAGHT EASYCLAD can be attached to the supporting frame with the panels either running vertical or horizontal.

The first panel is held in place by a starting clip or by a trim channel fitted over the panel. The underlapping side of this panel is then fastened to each support adjacent to the return lip. The next panel is then overlapped and hooked over the return lip, with the underlapping side being fastened as previous. The laying of subsequent sheets follows this procedure.

Installation - Concealed Fastener through edge of panel

First Sheet
CD 40 Clip



First Sheet
Trim channel



Intermediate Sheet



Final Sheet



Easyclad accessories

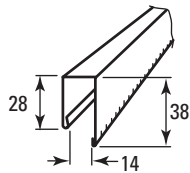

CD1 Trim channel

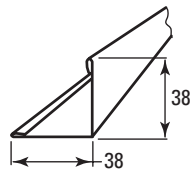

CD5 External corner trim

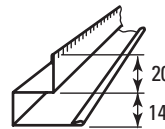

CD27 Fascia to soffit section

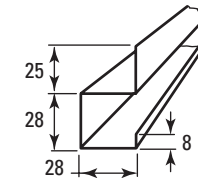

CD4 Feature section

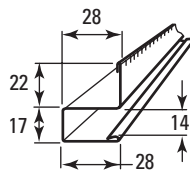

CD3 Fascia to soffit section

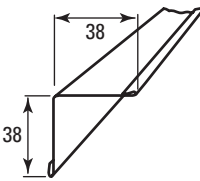

CD 6 Internal corner trim

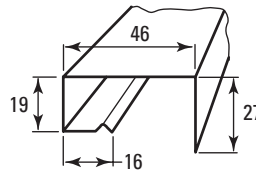

CD30 Fascia capping

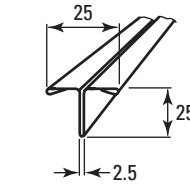

CD15 Tee section

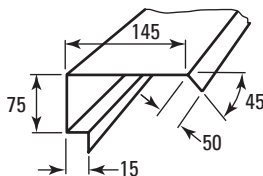

EC3 Fascia capping

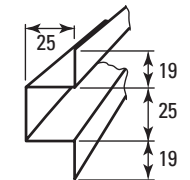

CD8 Purlin hat section

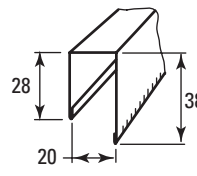

CD39 Trim channel

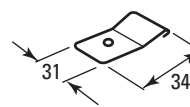

CD40 Starting clip

Disclaimer, warranties and limitation of liability

This publication is intended to be an aid for all trades and professionals involved with specifying and installing Lysaght products and not to be a substitute for professional judgement.

Terms and conditions of sale available at local BlueScope Lysaght sales offices.

Except to the extent to which liability may not lawfully be excluded or limited, BlueScope Steel Limited will not be under or incur any liability to you for any direct or indirect loss or damage (including, without limitation, consequential loss or damage such as loss of profit or anticipated profit, loss of use, damage to goodwill and loss due to delay) however caused (including, without limitation, breach of contract, negligence and/or breach of statute), which you may suffer or incur in connection with this publication.

© Copyright BlueScope Steel Limited, September 25, 2008

www.lysaght.com

Information, brochures and your local distributor

1800 641 417

Please check the latest information which is always available at www.lysaght.com

LYSAGHT, EASYCLAD, COLORBOND and ZINCALUME are registered trademarks of BlueScope Steel Limited, ABN 16 000 011 058. The LYSAGHT® range of products is exclusively made by BlueScope Steel Limited trading as BlueScope Lysaght.

Printed by BMP1M1008

